

ORDINANCE NO. 757

VILLAGE OF BELLEVUE, ILLINOIS

AN ORDINANCE REGARDING
EXCAVATION WITHIN RIGHT OF WAYS

WHEREAS, the Village Board of Trustees has concerns regarding excavation or other similar work performed within Village right of ways;

WHEREAS, Section 11-80-2 of the Illinois Municipal Code (65 ILCS 5/11-80-2) authorizes the corporate authorities of municipalities to regulate the use of streets and other municipal property; and

WHEREAS, the Board has determined that the regulation of excavation and other similar work is necessary for the health, safety and welfare of the Village and its residents;

NOW, THEREFORE, BE IT ORDAINED BY THE PRESIDENT AND THE BOARD OF TRUSTEES OF THE VILLAGE OF BELLEVUE, PEORIA COUNTY, ILLINOIS AS FOLLOWS:

SECTION 1: Permit and Bond Required

No public street, alley, curb or sidewalk, or area within two (2) feet thereof, within the Village may be cut or opened by any person or entity (an "Excavator") without (i) obtaining a permit from the Village Street Superintendent, except in case of any emergency, at which time the Street Superintendent will be notified and a permit obtained within the first normal working day, and (ii) providing financial security as set forth below. The fee for a permit shall be Twenty-Five Dollars (\$25.00).

The Excavator shall provide financial security to the Village to assure the restoration and/or repair of the rights-of-way or any other public property. The financial security shall be in the form of a cashier's check or payment and performance bonds. The amount of the cashier's check or bonds shall be determined by the Village per right-of-way opening application based on the anticipated scope of work. The financial security shall be held by the Village until the Village deems the project complete.

The Village shall notify the Excavator if the Village believes that the Excavator has failed to restore and/or repair Village right-of-way or other public property in accordance with this Ordinance and intends to utilize the financial security for proper restoration and/or repair of the rights-of-way or any other public property. The Excavator shall have 5 days (unless additional time is granted by the Village) after notification by the Village to restore and/or repair those areas noted by the Village at his/her own expense. After the 5 days, the Village may utilize the financial security for restoration and/or repair of the rights-of-way or any other public property.

SECTION 2: Liability Insurance and Indemnification

- (a) Each Excavator shall be insured against liability for injuries and damages caused

by its negligence in an amount appropriate for the operations engaged in, and shall hold the Village free and harmless from all costs and expenses (including attorneys' fees) incurred by the Village as a result of damage and injuries caused by the negligence of the Excavator in the performance of the work.

(b) Exempt from the liability insurance requirements set forth in this section (but not the indemnification provisions) are:

- (1) Public utilities regulated by the state commerce commission.
- (2) Entities holding a franchise from the Village.
- (3) Municipal corporations of the State of Illinois.

SECTION 3: Responsibility for Maintenance

Any Excavator who performs excavation or similar work within Village right-of-way shall repair any defects and shall, at the conclusion of the work, restore the area as set forth in this Ordinance.

SECTION 4: Protective Measures

(a) It shall be the duty of every Excavator performing excavation or similar work within Village right of way to place and maintain barriers and warning devices necessary for safety of the general public, providing that such work is undertaken in a manner which is safe.

(b) The Excavator shall arrange the work area in such manner as to create the least inconvenience possible to the occupants of the adjoining property and to the general public.

SECTION 5: Clearance for Vital Structures

No excavation or similar work within Village right of way shall interfere with access to fire hydrants, fire stations, fire escapes, water gates, underground vaults, valve housing structures and all other vital equipment, except as authorized by the Village Board in writing.

SECTION 6: Cleanup

All property shall be thoroughly cleaned of all rubbish, excess earth, rock and other debris resulting from the excavation or similar work during (to the extent practical) and not later than four (4) hours after such material is deposited, or at the end of each work day, whichever occurs first. If the Excavator performing the work fails to perform required clean up work within such time, such work may be done by the Village and the cost thereof charged to the Excavator.

SECTION 7: Cleanup and Restoration

(a) Unless the Village chooses to require the payment pursuant to subsection 7(d) below, the Excavator shall restore the right-of-way as provided herein. The Excavator shall remove all excess material and restore all rights-of-way, turf and terrain and other property within five days after any portion of the rights-of-way are disturbed, damaged or destroyed due to construction or maintenance by the Excavator to a condition substantially equivalent to that which existed prior to the commencement of the project as determined by the Village Engineer.

Restoration work may include repairing entrances and side streets, backfilling, regrading, reseeding, and resodding. All restoration work shall be approved by the Village Engineer.

(b) Restoration of rights-of-way surfaces shall be made using materials and methods provided in this subsection or otherwise approved by the Village Engineer.

(1) Streets. Restoration of streets shall be as follows:

a. The Excavator shall construct a permanent patch consisting of a minimum of eight inches of PCC for concrete streets and four inches of bituminous concrete for bituminous surfaced streets on all excavation openings. In general, the Excavator shall construct a permanent patch consisting of a minimum of eight inches of PCC for concrete streets and four inches of bituminous concrete for bituminous surfaced streets on all excavation openings. The surface shall have a minimum two percent transverse slope. The surface shall be of positive drainage and no standing water shall exist. Any patch over 50 feet long shall be completed with a paving machine.

b. If surface repairs constitute more than 50 percent of a 50-foot segment of a street as measured from the beginning of any repair to the end of any other repair, the Excavator, at its expense, shall resurface that section of the street. The section of the street to be resurfaced shall be determined by the Village Engineer based on the disturbance: at the minimum it shall mean the full width of the traffic lane or to the seam of the original overlay; at the maximum it shall mean the entire width of the street. Resurface shall mean a minimum of 1.5" mill and 1.5" hot mix asphalt resurface. Resurfacing shall be completed with a paving machine. The surface shall have a minimum two percent transverse slope. The surface shall be of positive drainage and no standing water shall exist.

c. If more than three pavement repairs are made in any 100-foot section of a street, the Excavator, at its expense, shall resurface that section of the street. The section of the street to be resurfaced shall be determined by the Village Engineer based on the disturbance: at the minimum it shall mean the full width of the traffic lane or to the seam of the original overlay; at the maximum it shall mean the entire width of the street. Resurface shall mean a minimum of 1.5" mill and 1.5" hot mix asphalt resurface. Resurfacing shall be completed with a paving machine. The surface shall have a minimum two percent transverse slope. The surface shall be of positive drainage and no standing water shall exist.

(2) Sidewalks. Restoration of sidewalks shall consist of a minimum of a four-inch aggregate base course under a minimum of four inches of PCC.

(c) The time period provided in this Section may be extended by the Village Engineer for good cause shown.

(d) In the event the Village plans a future improvement to the right-of-way, the Village has the option to require the Excavator to make a payment to the Village, rather than performing the restoration. The amount of such payment shall be the amount of the cost estimate obtained from a contractor of the Village's choice, plus engineering costs equal to ten percent of the cost estimate.

(e) Facilities are to be maintained by or for the Excavator in a manner satisfactory to the Village and at the Excavator's expense.

(f) Any Excavator who performs restoration work on a right-of-way pursuant to a permit issued under this ordinance shall be responsible for the repair of any defects and the maintenance of the restoration work from the time the restoration work is made until such time as the right-of-way is either overlaid or repaved.

(g) The Excavator shall be responsible for correcting any drainage/roadway issues occurring as a result of the Excavator's permit activities. Any drainage/roadway issues in the area of the Excavator's excavation shall be deemed as a result of the Excavator's permit activities unless the Excavator can prove otherwise. All issues shall be resolved to the satisfaction of the Village's Street Superintendent.

(h) The following requirements shall also be met:

- Cold patches are temporary and must be replaced with hot mix asphalt when conditions permit.
- Asphalt patches must be a minimum of 4" thick and properly compacted with a steel drum roller.
- Edges of all patches must be saw cut, leaving a clean, solid surface to place asphalt against.
- When a concrete street or an overlaid concrete street is to be opened, the concrete must be replaced a minimum of 8" thick or to the thickness of the existing pavement.
- All grass areas disturbed must be properly graded, seeded and mulched with a straw type mat.

(i) All work shall be performed in accordance with the construction standards attached hereto.

SECTION 8: Compliance with Laws

The Excavator shall comply with all laws, ordinances, orders, rules and regulations of all municipal, county, state, federal or other governmental authorities applicable to the excavation, including, without limitation, Village Ordinances 274 and 580.

SECTION 9: Liability of Village

This Ordinance shall not be construed as imposing upon the Village or any official or employee any liability or responsibility for damages to any person injured by the performance of any work under this Ordinance, nor shall the Village or any official or employee thereof be deemed to have assumed any such liability or responsibility by reason of inspections or tests authorized hereunder.

SECTION 10: Covered Parties

The provisions of this Ordinance shall apply to both contractors actually performing excavation work as well as the utility company, property owner or other entity for whom the work is being performed.

SECTION 11: Penalty

Any person convicted of violating any section of this Ordinance shall be fined not less than \$100.00 nor more than \$750.00 and shall be liable to the Village for all costs and expenses necessarily expended by the Village in correcting any injury or damage caused by his violation. Each day that a violation of this Ordinance continues shall be considered a separate violation of this Ordinance.

SECTION 12: Prior Ordinances

This Ordinance is an amendment and restatement of Village of Bellevue Ordinance Nos. 417, 452 and 558, and those Ordinances are hereby repealed.

Passed and approved by the President and the Board of Trustees of the Village of Bellevue, Illinois, this 13 day of March 2018.

AYES: 4
NAYS: 0
ABSENT: 2

VILLAGE OF BELLEVUE, ILLINOIS

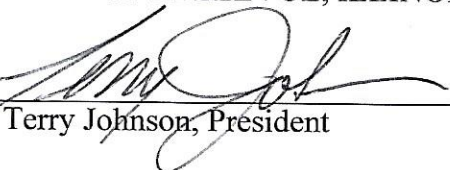
By: 
Terry Johnson, President

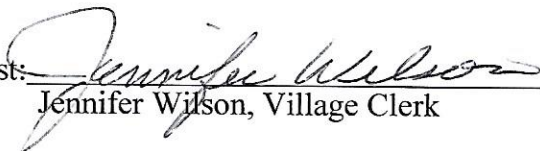
Attest: 
Jennifer Wilson, Village Clerk

TYPICAL STREET REPAIR FOR UNDERGROUND UTILITY INSTALLATION BITUMINOUS PAVEMENTS

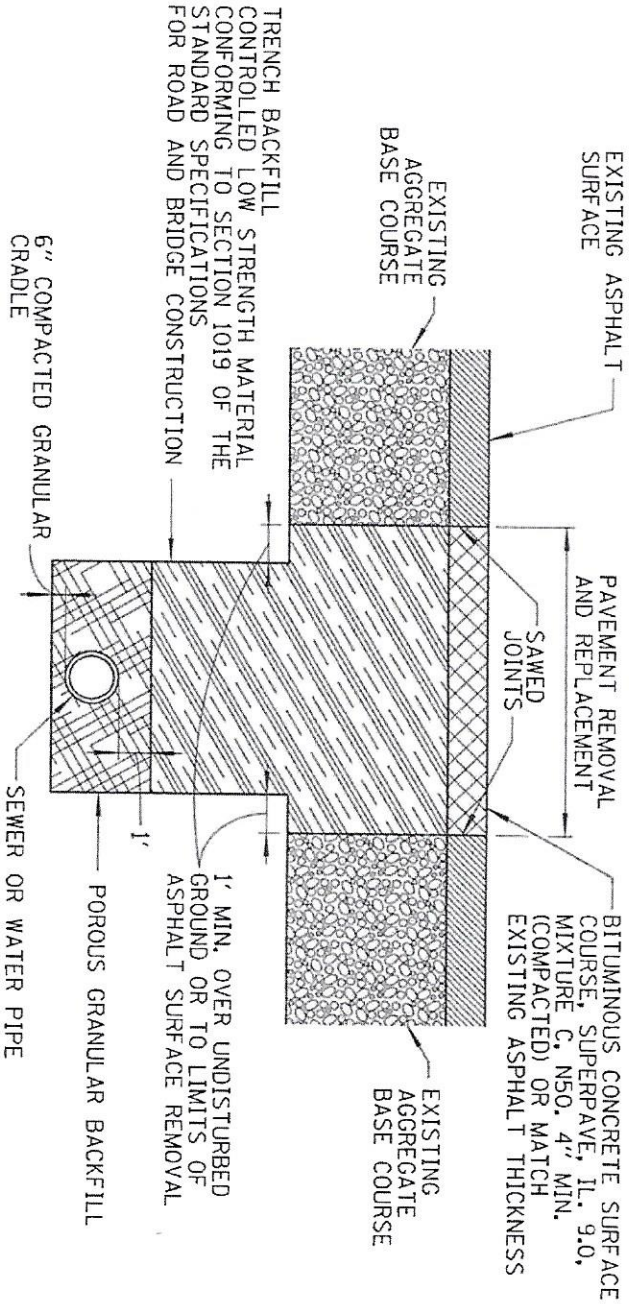

GENERAL NOTE:

ALL EXCAVATION, REPLACEMENT AND CLEAN-UP WORK SHALL BE DONE IN ACCORDANCE WITH THE APPLICABLE PROVISIONS OF THE "STANDARD SPECIFICATIONS FOR WATER AND SEWER MAIN CONSTRUCTION IN ILLINOIS" AND THE IDOT "STANDARD SPECIFICATIONS FOR ROAD AND BRIDGE CONSTRUCTION", CURRENT EDITIONS.

NOTES:

IF BITUMINOUS CONCRETE MATERIAL IS NOT AVAILABLE DUE TO SEASONAL CLOSING OF ASPHALT PLANTS, A TEMPORARY SURFACE CONSISTING OF A MINIMUM 4" OF BITUMINOUS COLD PATCH MIXTURE SHALL BE APPLIED UNTIL THE "HOT MIX" BITUMINOUS MATERIAL IS AVAILABLE.

Construction Standard	Date	Standard No.
	Feb., 2008	R-8

PAV0206N.CIVIL.ExhibtSV-R.dgn

10/26/2009

TYPICAL STREET REPAIR FOR UNDERGROUND UTILITY INSTALLATION CONCRETE PAVEMENTS

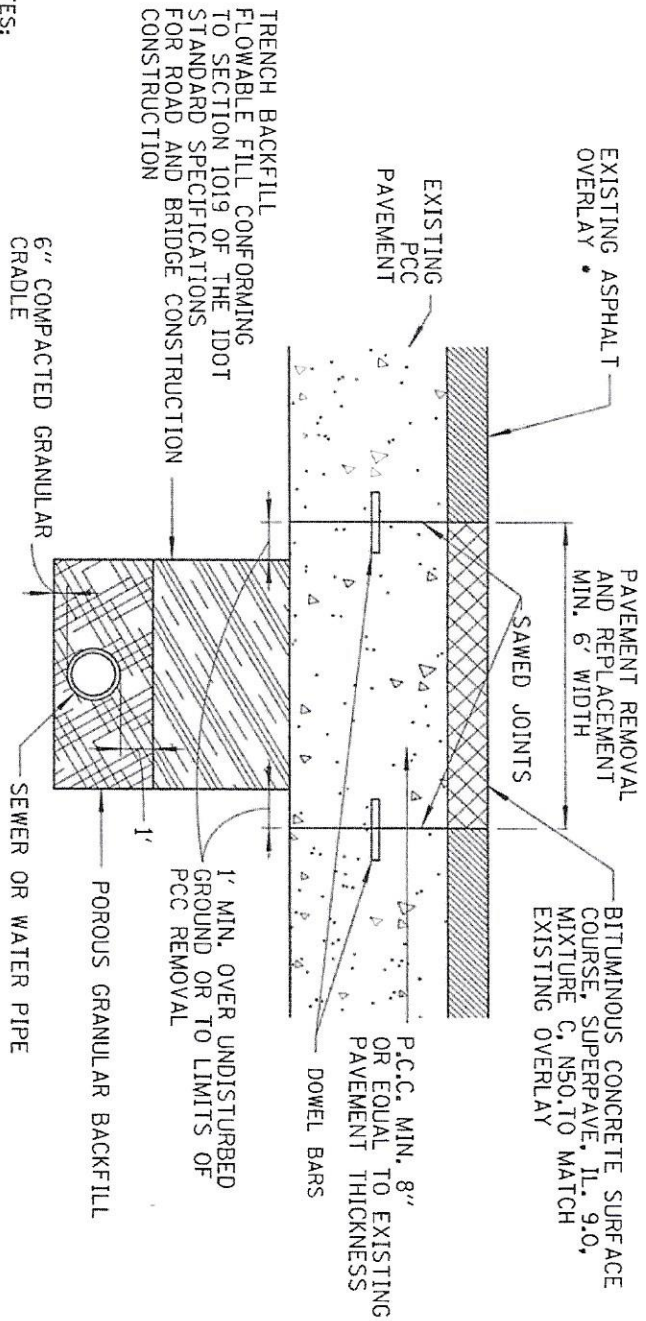

TRENCH BACKFILL FLOWABLE FILL CONFORMING TO SECTION 1019 OF THE IDOT STANDARD SPECIFICATIONS FOR ROAD AND BRIDGE CONSTRUCTION

NOTES:

1. SEE IDOT STD. 442101-07 (TYPE B PATCHES) FOR DOWEL BAR SIZE AND SPACING AND OTHER DETAILS.
2. SEE SECTION 442 OF THE IDOT STANDARD SPECIFICATIONS FOR CONSTRUCTION DETAILS.
3. MIN. PATCH WIDTH IS 6' MIN. PATCH LENGTH IS 6' IF PATCH IS OVER 6' IN LENGTH, PATCH SHOULD EXTEND TO THE FIRST LONGITUDINAL JOINT.
4. WHERE CONCRETE PAVEMENT HAS NOT BEEN OVERLAYED THE PCC PATCH WILL SERVE AS THE DRIVING SURFACE.
5. FOR BRICK PAVEMENTS, THE BRICK PORTION SHALL BE REPLACED WITH 8" PCC PAVEMENT.
6. IF BITUMINOUS CONCRETE MATERIAL IS NOT AVAILABLE DUE TO SEASON CLOSING OF ASPHALT PLANTS, A TEMPORARY SURFACE CONSISTING OF BITUMINOUS COLD PATCH MIXTURE SHALL BE APPLIED UNTIL THE "HOT MIX" BITUMINOUS MATERIAL IS AVAILABLE.

GENERAL NOTE:
ALL EXCAVATION, REPLACEMENT AND CLEAN-UP WORK SHALL BE DONE IN ACCORDANCE WITH THE APPLICABLE PROVISIONS OF THE "STANDARD SPECIFICATIONS FOR WATER AND SEWER MAIN CONSTRUCTION IN ILLINOIS" AND THE IDOT "STANDARD SPECIFICATIONS FOR ROAD AND BRIDGE CONSTRUCTION", CURRENT EDITIONS.

Construction Standard		
Date	Feb. 2008	Standard No.
		R-9

P:\10726\GWIN\EXHIBITS\13\13dot1

10726/2008

**DRIVEWAY ENTRANCE DETAIL FOR
CURB OPENINGS WITH CURB LINE SIDEWALK**

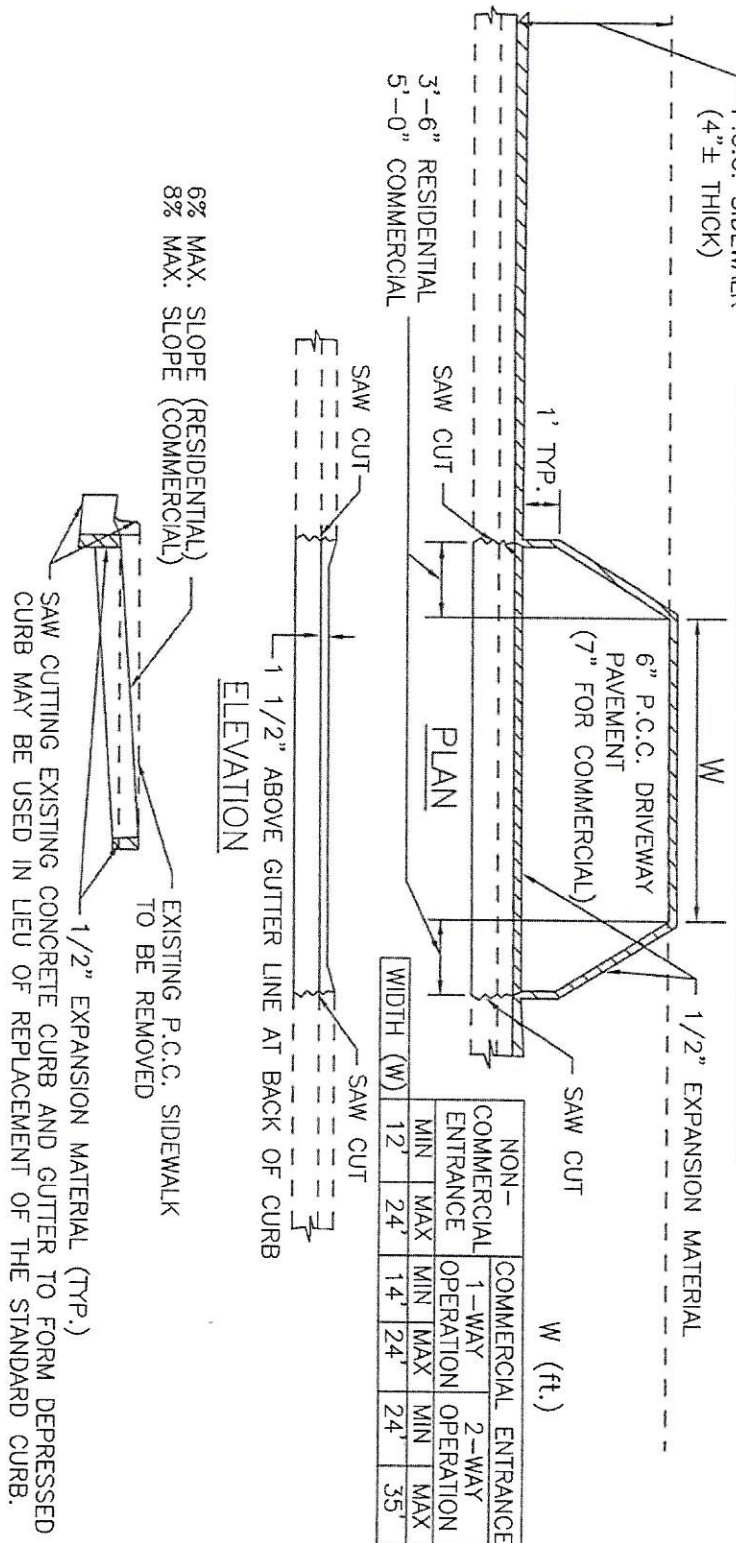

WIDTH (W)	NON-COMMERCIAL ENTRANCE		COMMERCIAL ENTRANCE	
	MIN	MAX	MIN	MAX
12'	24'	14'	24'	35'

W (ft.)

SECTION

- GENERAL NOTES:**
- CONSTRUCTION SHALL BE IN ACCORDANCE WITH THE STATE OF ILLINOIS "STANDARD SPECIFICATIONS FOR ROAD AND BRIDGE CONSTRUCTION" CURRENT EDITION AND SUPPLEMENTAL SPECIFICATIONS, UNLESS OTHERWISE DIRECTED BY THE ENGINEER.
 - SIDEWALK GRADES MUST BE MAINTAINED AT THE FACE OF WALK, SEE IDOT DISTRICT CADD STANDARD 423101-D4.
 - SIDEWALK AND CURB & GUTTER SHALL BE SAWED (FULL DEPTH) AT THE BEGINNING AND END OF THE REMOVAL SECTION.
 - WHERE NO SIDEWALK EXISTS, THE DRIVE SHALL BE CONSTRUCTED AS SHOWN TO ACCOMMODATE FUTURE SIDEWALK.
 - WHEN DRIVEWAY OPENING IS PROVIDED AT THE TIME OF CURB CONSTRUCTION, CONTRACTION JOINTS SHALL BE PLACED AT THE LOCATION OF THE SAW CUTS AS SHOWN.
 - ALL SAW CUTS MUST BE A MINIMUM OF 1" DEEP.
 - IN NO CASE SHALL CURB OPENING BE CONSTRUCTED BEYOND EXTENDED PROPERTY LINE OF ADJOINING PROPERTY.

CONSTRUCTION STANDARD		STANDARD NO.	
DATE:	JAN. 1998	STANDARD NO.	DR-1

DRIVEWAY ENTRANCE DETAIL FOR CURB OPENINGS WITH SIDEWALK/PARKWAY

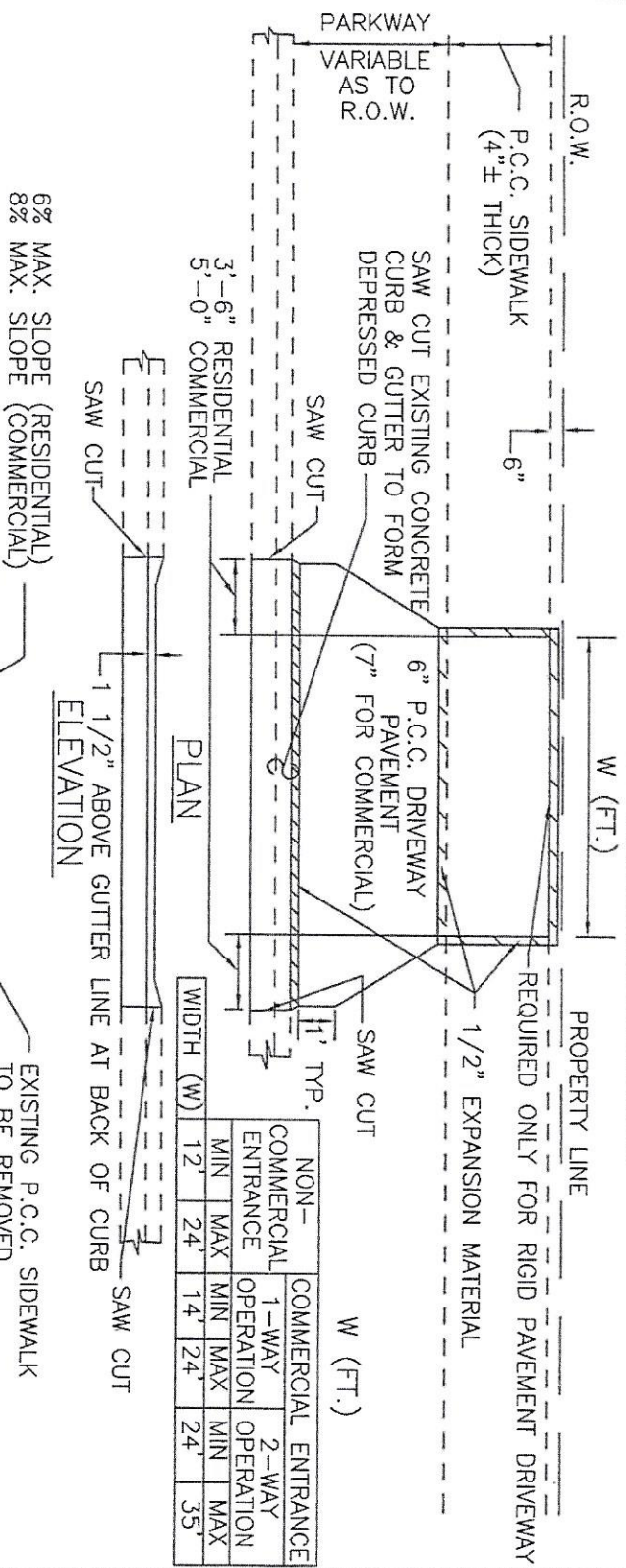

	NON-COMMERCIAL ENTRANCE		COMMERCIAL OPERATION		COMMERCIAL ENTRANCE	
	MIN	MAX	MIN	MAX	MIN	MAX
WIDTH (W)	12'	24'	14'	24'	24'	35'

GENERAL NOTES:

1. CONSTRUCTION SHALL BE IN ACCORDANCE WITH THE STATE OF ILLINOIS "STANDARD SPECIFICATIONS FOR ROAD AND BRIDGE CONSTRUCTION" CURRENT EDITION AND SUPPLEMENTAL SPECIFICATIONS, UNLESS OTHERWISE DIRECTED BY THE ENGINEER.
2. SIDEWALK GRADES MUST BE MAINTAINED AT THE FACE OF WALK.
3. SIDEWALK AND CURB & GUTTER SHALL BE SAWS (FULL DEPTH) AT THE BEGINNING AND END OF THE REMOVAL SECTION.
4. WHERE NO SIDEWALK EXISTS, THE DRIVE SHALL BE CONSTRUCTED AS SHOWN TO ACCOMMODATE FUTURE SIDEWALK.
5. WHEN DRIVEWAY OPENING IS PROVIDED AT THE TIME OF CURB CONSTRUCTION, CONTRACTION JOINTS SHALL BE PLACED AT THE LOCATION OF THE SAW CUTS AS SHOWN.
6. ALL SAW CUTS MUST BE A MINIMUM OF 1" DEEP.
7. IN NO CASE SHALL CURB OPENING BE CONSTRUCTED BEYOND EXTENDED PROPERTY LINE OF ADJOINING PROPERTY.

SECTION

CONSTRUCTION STANDARD

DATE:	STANDARD NO.
JAN. 1998	DR-2

DRIVEWAY ENTRANCE DETAIL WITHOUT CURB OPENING

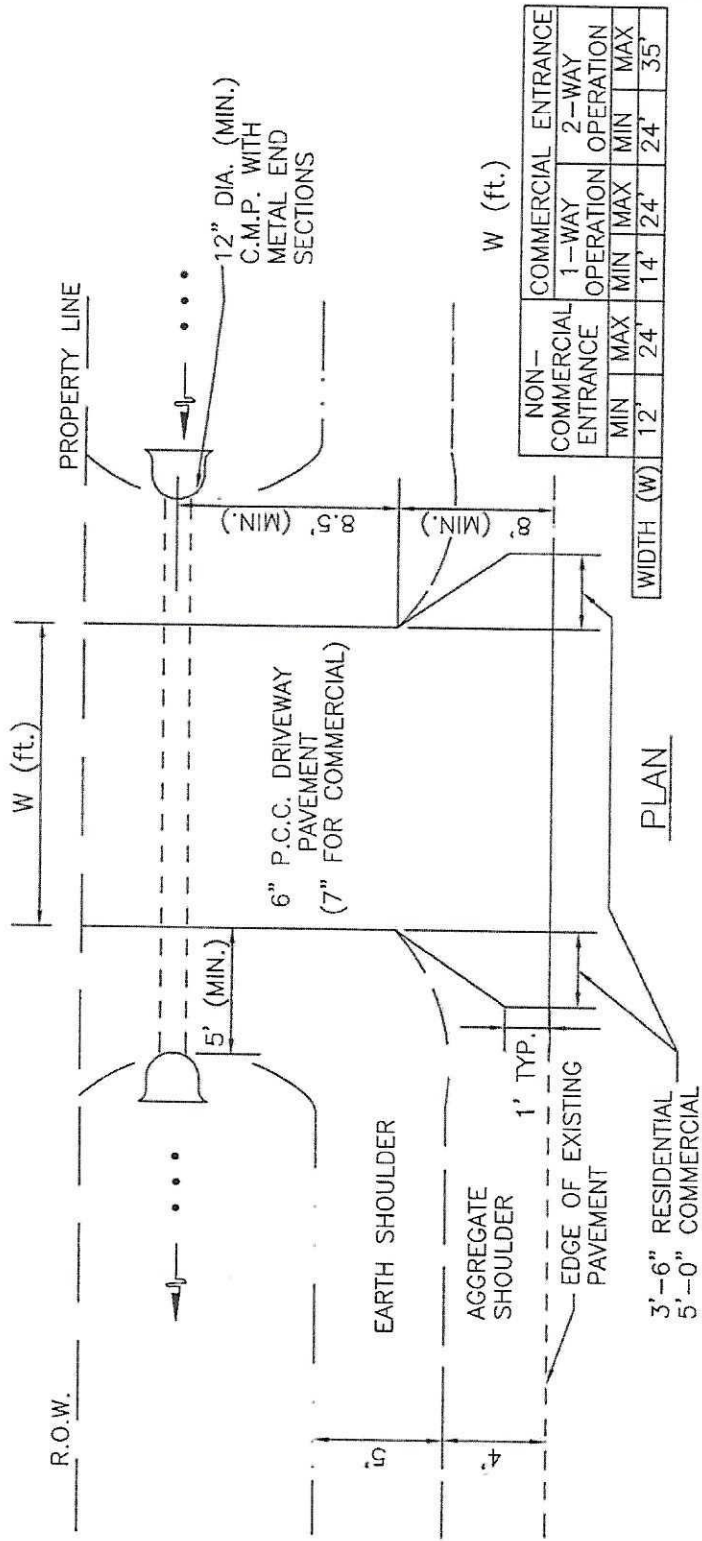

NON-COMMERCIAL ENTRANCE		COMMERCIAL ENTRANCE	
MIN	MAX	MIN	MAX
12'	24'	14'	24'
OPERATION		OPERATION	
14'	24'	24'	35'

GENERAL NOTES:

- CONSTRUCTION SHALL BE IN ACCORDANCE WITH THE STATE OF ILLINOIS "STANDARD SPECIFICATIONS FOR ROAD & BRIDGE CONSTRUCTION" CURRENT EDITION AND SUPPLEMENTAL SPECIFICATIONS, UNLESS OTHERWISE DIRECTED BY THE ENGINEER.
- IN NO CASE SHALL THE DRIVEWAY PAVEMENT BE CONSTRUCTED BEYOND EXTENDED PROPERTY LINE OF ADJOINING PROPERTY.
- THE CULVERT SHALL BE CONSTRUCTED TO MEET THE EXISTING DITCH GRADES.

CONSTRUCTION STANDARD	DATE: JAN. 1998
STANDARD NO. DR-3	